

### ◆ 8.3 6T1 7T1 IE1 trifase / three-phase motor

56-132 B3

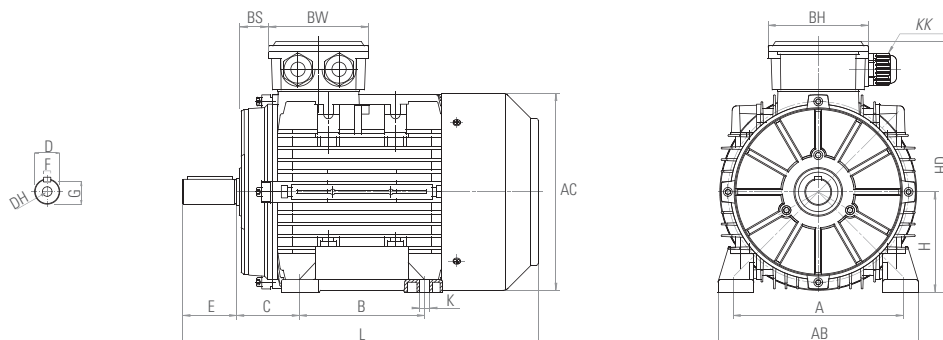

160-280 B3

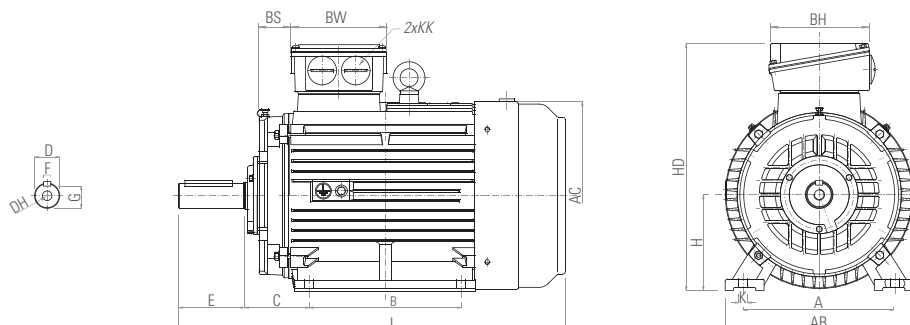

315-355 B3

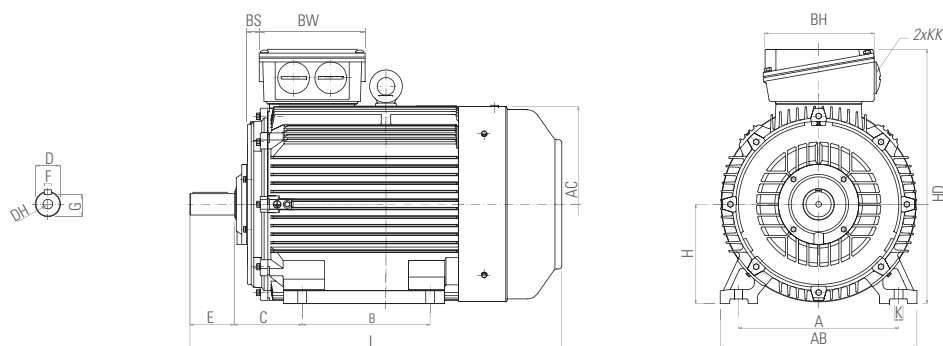

355LX-450 B3

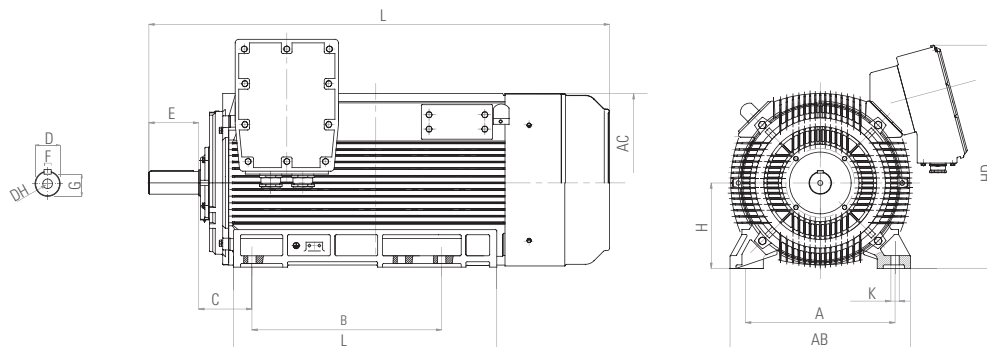

## 56÷450

B3	A	AB	B	C	K	AC	HD	D	DH	E	F	G	H	KK	L	BS	BW	BH
56-132 B3																		
56	90	110	71	36	5.8X8.8	115	153	9	M3X8	20	3	7.2	56	M20X1.5	195	14	88	88
63	100	120	80	40	7X10	130	168	11	M4X10	23	4	8.5	63	M20X1.5	215	14	94	94
71	112	132	90	45	7X10	145	183	14	M5X12	30	5	11	71	M20X1.5	255	20	94	94
80	125	160	100	50	10X15	165	210	19	M6X16	40	6	15.5	80	M20X1.5	277	27	105	105
90S	140	175	100	56	10X15	185	230	24	M8X20	50	8	20	90	M20X1.5	312	26	105	105
90L	140	175	125	56	10X15	185	230	24	M8X20	50	8	20	90	M20X1.5	337	26	105	105
100L	160	196	140	63	12X16	205	255	28	M10X22	60	8	24	100	M20X1.5	375	26	105	105
112	190	220	140	70	12X16	230	278	28	M10X22	60	8	24	112	M25X1.5	400	34	112	112
132S	216	252	140	89	12X16	270	320	38	M12X28	80	10	33	132	M25X1.5	460	40	112	112
132M	216	252	178	89	12X16	270	320	38	M12X28	80	10	33	132	M25X1.5	500	40	112	112
160-280 B3																		
160M	254	320	210	108	14X19	330	425	42	M16X36	110	12	37	160	M32X1.5	605	92	150	180
160L	254	320	254	108	14X19	330	425	42	M16X36	110	12	37	160	M32X1.5	650	92	150	180
180M	279	350	241	121	14X22	380	460	48	M16X36	110	14	42.5	180	M32X1.5	675	92	150	180
180L	279	350	279	121	14X22	380	460	48	M16X36	110	14	42.5	180	M32X1.5	715	92	150	180
200L	318	395	305	133	18X25	420	515	55	M20X42	110	16	49	200	M40X1.5	765	100	180	215
225S4	356	436	286	149	18X28	465	560	60	M20X42	140	18	53	225	M40X1.5	820	100	180	215
225M2	356	436	311	149	18X28	465	560	55	M20X42	110	16	49	225	M40X1.5	815	100	180	215
225M4-8	356	436	311	149	18X28	465	560	60	M20X42	140	18	53	225	M40X1.5	845	100	180	215
250M2	406	495	349	168	24X33	520	625	60	M20X42	140	18	53	250	M50X1.5	930	105	215	260
250M4-8	406	495	349	168	24X33	520	625	65	M20X42	140	18	58	250	M50X1.5	930	105	215	260
280S2	457	550	368	190	24X35	570	685	65	M20X42	140	18	58	280	M50X1.5	960	105	215	260
280S4-8	457	550	368	190	24X35	570	685	75	M20X42	140	20	67.5	280	M50X1.5	975	105	215	260
280M2	457	550	419	190	24X35	570	685	65	M20X42	140	18	58	280	M50X1.5	1000	105	215	260
280M4-8	457	550	419	190	24X35	570	685	75	M20X42	140	20	67.5	280	M50X1.5	1015	105	215	260
315-355 B3																		
315S2	508	630	406	216	28X45	620	815	65	M20X42	140	18	58	315	M63X1.5	1150	105	285	330
315S4-8	508	630	406	216	28X45	620	815	80	M20X42	170	22	71	315	M63X1.5	1185	105	285	330
315M2	508	630	457	216	28X45	620	815	65	M20X42	140	18	58	315	M63X1.5	1260	105	285	330
315M4-8	508	630	457	216	28X45	620	815	80	M20X42	170	22	71	315	M63X1.5	1295	105	285	330
315L2	508	630	508	216	28X45	620	815	65	M20X42	140	18	58	315	M63X1.5	1265	105	285	330
315L4-8	508	630	508	216	28X45	620	815	80	M20X42	170	22	71	315	M63X1.5	1305	105	285	330
355M2	610	735	560	254	28X49	700	1000	75	M24X50	140	20	67.5	355	M63X1.5	1510	100	360	410
355M4-8	610	735	560	254	28X49	700	1000	100	M24X50	210	28	86	355	M63X1.5	1570	100	360	410
355L2	610	735	630	254	28X49	700	1000	75	M24X50	140	20	67.5	355	M63X1.5	1610	100	360	410
355L4-8	610	735	630	254	28X49	700	1000	100	M24X50	210	28	86	355	M63X1.5	1640	100	360	410
355LX-400 B3																		
355LX2	630	760	800	254	35	760	980	75	M20X42	140	20	67.5	355	-/-	1855	105	430	485
355LX4-8	630	760	800	254	35	760	980	100	M20X42	210	28	86	355	-/-	1950	105	430	485
400 2	710	840	900	280	35	840	1060	85	M24X50	170	22	76	400	-/-	1910	147	430	485
400 4-8	710	840	900	280	35	840	1060	120	M24X50	210	32	109	400	-/-	1990	147	430	485
450 2	800	990	1000	250	42	990	1390	95	M24X50	170	25	86	450	-/-	2120	190	460	530
450 4-8	800	990	1000	250	42	990	1390	130	M24X50	210	32	119	450	-/-	2160	190	460	530

Dati tecnici e caratteristiche possono subire variazioni / Technical data and performances may change

6T1 7T1 IE1 trifase / *three-phase motor*

56-132 B5

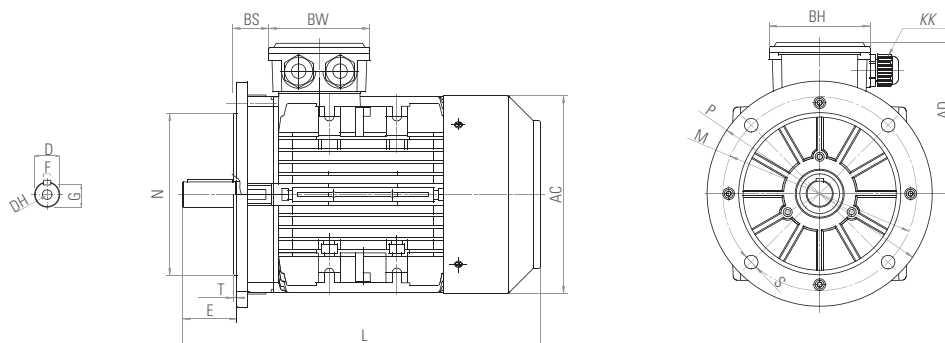

160-280 B5

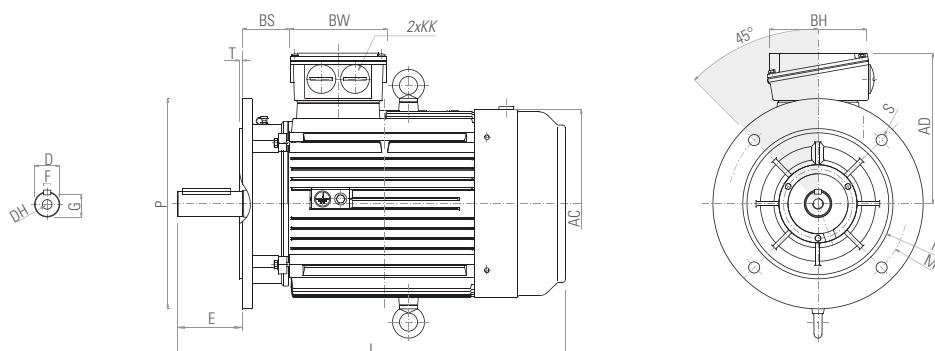

315-355 B5

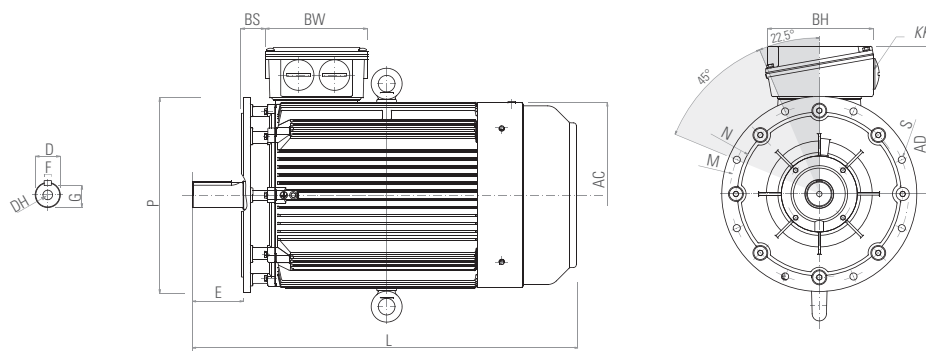

355LX-450 B5

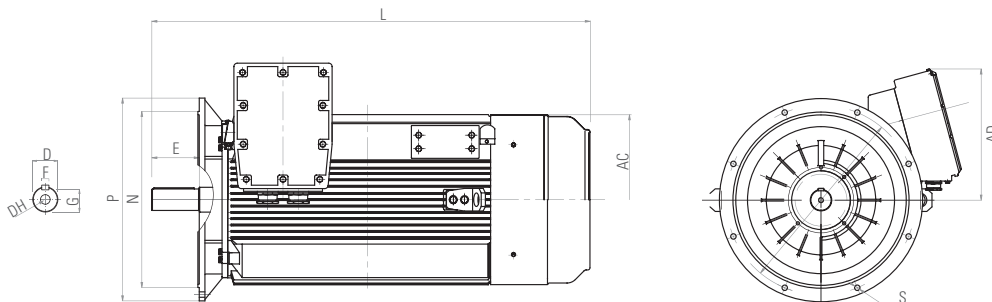

## 56÷450

B5	P	M	N	S	T	AC	AD	D	DH	E	F	G	H	KK	L	BS	BW	BH
<b>56-132 B5</b>																		
56	120	100	80	7	3	115	97	9	M3X8	20	3	7.2	56	M16X1.5	195	14	88	88
63	140	115	95	10	3	130	105	11	M4X10	23	4	8.5	63	M16X1.5	215	14	94	94
71	160	130	110	10	3.5	145	112	14	M5X12	30	5	11	71	M20X1.5	255	20	94	94
80	200	165	130	12	3.5	165	130	19	M6X16	40	6	15.5	80	M20X1.5	277	27	105	105
90S	200	165	130	12	3.5	185	140	24	M8X20	50	8	20	90	M20X1.5	312	26	105	105
90L	200	165	130	12	3.5	185	140	24	M8X20	50	8	20	90	M20X1.5	337	26	105	105
100L	250	215	180	15	4	205	155	28	M10X22	60	8	24	100	M20X1.5	375	26	105	105
112	250	215	180	15	4	230	166	28	M10X22	60	8	24	112	M25X1.5	400	34	112	112
132S	300	265	230	15	4	270	188	38	M12X28	80	10	33	132	M25X1.5	460	40	112	112
132M	300	265	230	15	4	270	188	38	M12X28	80	10	33	132	M25X1.5	500	40	112	112
<b>160-280 B5</b>																		
160M	350	300	250	18.5	5	330	265	42	M16X36	110	12	37	160	M32X1.5	605	92	150	180
160L	350	300	250	18.5	5	330	265	42	M16X36	110	12	37	160	M32X1.5	650	92	150	180
180M	350	300	250	18.5	5	380	280	48	M16X36	110	14	42.5	180	M32X1.5	675	92	150	180
180L	350	300	250	18.5	5	380	280	48	M16X36	110	14	42.5	180	M32X1.5	715	92	150	180
200L	400	350	300	18.5	5	420	315	55	M20X42	110	16	49	200	M40X1.5	765	100	180	215
225S4	450	400	350	18.5	5	465	335	60	M20X42	140	18	53	225	M40X1.5	820	100	180	215
225M2	450	400	350	18.5	5	465	335	55	M20X42	110	16	49	225	M40X1.5	815	100	180	215
225M4-8	450	400	350	18.5	5	465	335	60	M20X42	140	18	53	225	M40X1.5	845	100	180	215
250M2	550	500	450	18.5	5	520	375	60	M20X42	140	18	53	250	M50X1.5	930	105	215	260
250M4-8	550	500	450	18.5	5	520	375	65	M20X42	140	18	58	250	M50X1.5	930	105	215	260
280S2	550	500	450	18.5	5	570	405	65	M20X42	140	18	58	280	M50X1.5	960	105	215	260
280S4-8	550	500	450	18.5	5	570	405	75	M20X42	140	20	67.5	280	M50X1.5	975	105	215	260
280M2	550	500	450	18.5	5	570	405	65	M20X42	140	18	58	280	M50X1.5	1000	105	215	260
280M4-8	550	500	450	18.5	5	570	405	75	M20X42	140	20	67.5	280	M50X1.5	1015	105	215	260
<b>315-355 B5</b>																		
315S2	660	600	550	24	6	620	500	65	M20X42	140	18	58	315	M63X1.5	1150	105	285	330
315S4-8	660	600	550	24	6	620	500	80	M20X42	170	22	71	315	M63X1.5	1185	105	285	330
315M2	660	600	550	24	6	620	500	65	M20X42	140	18	58	315	M63X1.5	1260	105	285	330
315M4-8	660	600	550	24	6	620	500	80	M20X42	170	22	71	315	M63X1.5	1295	105	285	330
315L2	660	600	550	24	6	620	500	65	M20X42	140	18	58	315	M63X1.5	1265	105	285	330
315L4-8	660	600	550	24	6	620	500	80	M20X42	170	22	71	315	M63X1.5	1305	105	285	330
355M2	800	740	680	24	6	700	645	75	M24X50	140	20	67.5	355	M63X1.5	1510	100	360	410
355M4-8	800	740	680	24	6	700	645	100	M24X50	210	28	86	355	M63X1.5	1640	100	360	410
355L2	800	740	680	24	6	700	645	75	M24X50	140	20	67.5	355	M63X1.5	1610	100	360	410
355L4-8	800	740	680	24	6	700	645	100	M24X50	210	28	86	355	M63X1.5	1640	100	360	410
<b>355LX-450 B5</b>																		
355LX2	900	840	780	24	6	760	625	75	M20X42	140	20	67.5	355	-/-	1855	105	430	485
355LX4-8	900	840	780	24	6	760	625	100	M20X42	210	28	86	355	-/-	1950	105	430	485
400 2	1000	940	880	28	6	840	660	85	M24X50	170	22	76	400	-/-	1910	147	430	485
400 4-8	1000	940	880	28	6	840	660	120	M24X50	210	32	109	400	-/-	1990	147	430	485
450 2	1150	1080	1000	28	6	1000	940	95	M24X50	170	25	86	450	-/-	2120	190	460	530
450 4-8	1150	1080	1000	28	6	1000	940	130	M24X50	210	32	119	450	-/-	2160	190	460	530

Nota: dal MEC225 incluso in su, la flangia B5 ha 8 fori di fissaggio. Dati tecnici e caratteristiche possono subire variazioni  
 Note: from MEC225 included onwards, the B5 flange has 8 mounting holes. Technical data and performances may change

## 6T1 7T1 IE1 trifase / three-phase motor

56÷160

56-132 B14

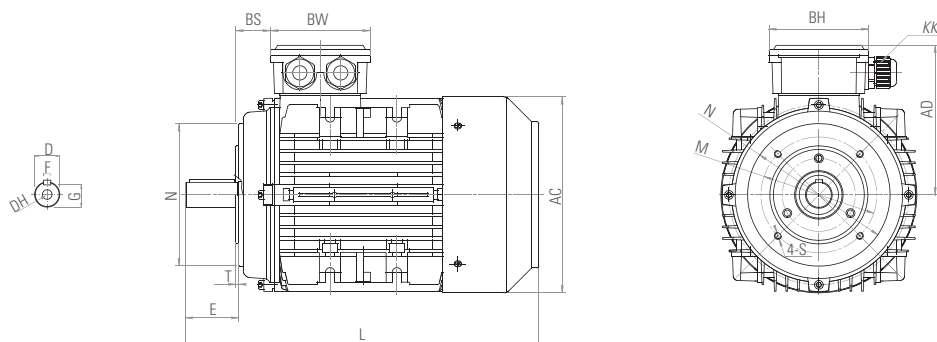

160 B14

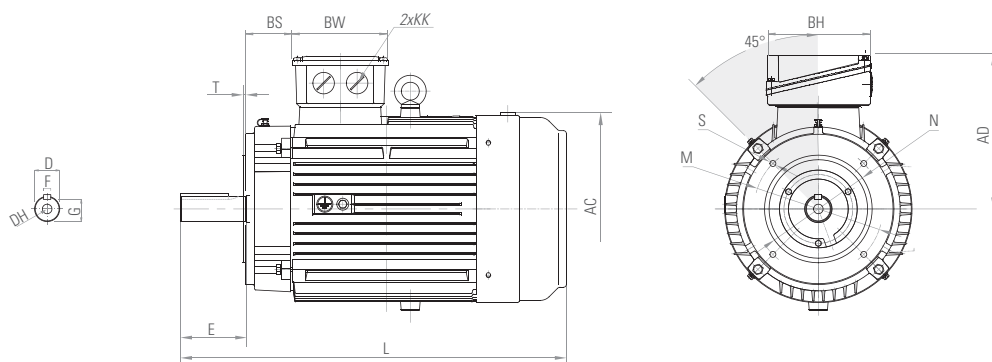

## B14

	P	M	N	S	T	AC	AD	D	DH	E	F	G	H	KK	L	BS	BW	BH
56-132 B14																		
56	80	65	50	M5	2.5	115	97	9	M3X8	20	3	7.2	56	M16X1.5	195	14	88	88
63	90	75	60	M5	2.5	130	105	11	M4X10	23	4	8.5	63	M16X1.5	215	14	94	94
71	105	85	70	M6	2.5	145	112	14	M5X12	30	5	11	71	M20X1.5	255	20	94	94
80	120	100	80	M6	3	165	130	19	M6X16	40	40	15.5	80	M20X1.5	277	27	105	105
90S	140	115	95	M8	3	185	140	24	M8X20	50	50	20	90	M20X1.5	312	26	105	105
90L	140	115	95	M8	3	185	140	24	M8X20	50	50	20	90	M20X1.5	337	26	105	105
100L	160	130	110	M8	3.5	205	155	28	M10X22	60	60	24	100	M20X1.5	375	26	105	105
112	160	130	110	M8	3.5	230	166	28	M10X22	60	60	24	112	M25X1.5	400	34	112	112
132S	200	165	130	M10	3.5	270	188	38	M12X28	80	80	33	132	M25X1.5	460	40	112	112
132M	200	165	130	M10	3.5	270	188	38	M12X28	80	80	33	132	M25X1.5	500	40	112	112
160 B14																		
160M	250	215	180	M12	4	330	265	42	M16X36	110	12	37	160	M32X1.5	605	92	150	180
160L	250	215	180	M12	4	330	265	42	M16X36	110	12	37	160	M32X1.5	650	92	150	180

Nota: fino al MEC71 incluso, la flangia B14 standard ha 8 fori di fissaggio. Dati tecnici e caratteristiche possono subire variazioni  
 Note: up to MEC71 included, the standard B14 flange has 8 mounting holes. Technical data and performances may change