

• 6.16 JM DIMENSIONAL DATA

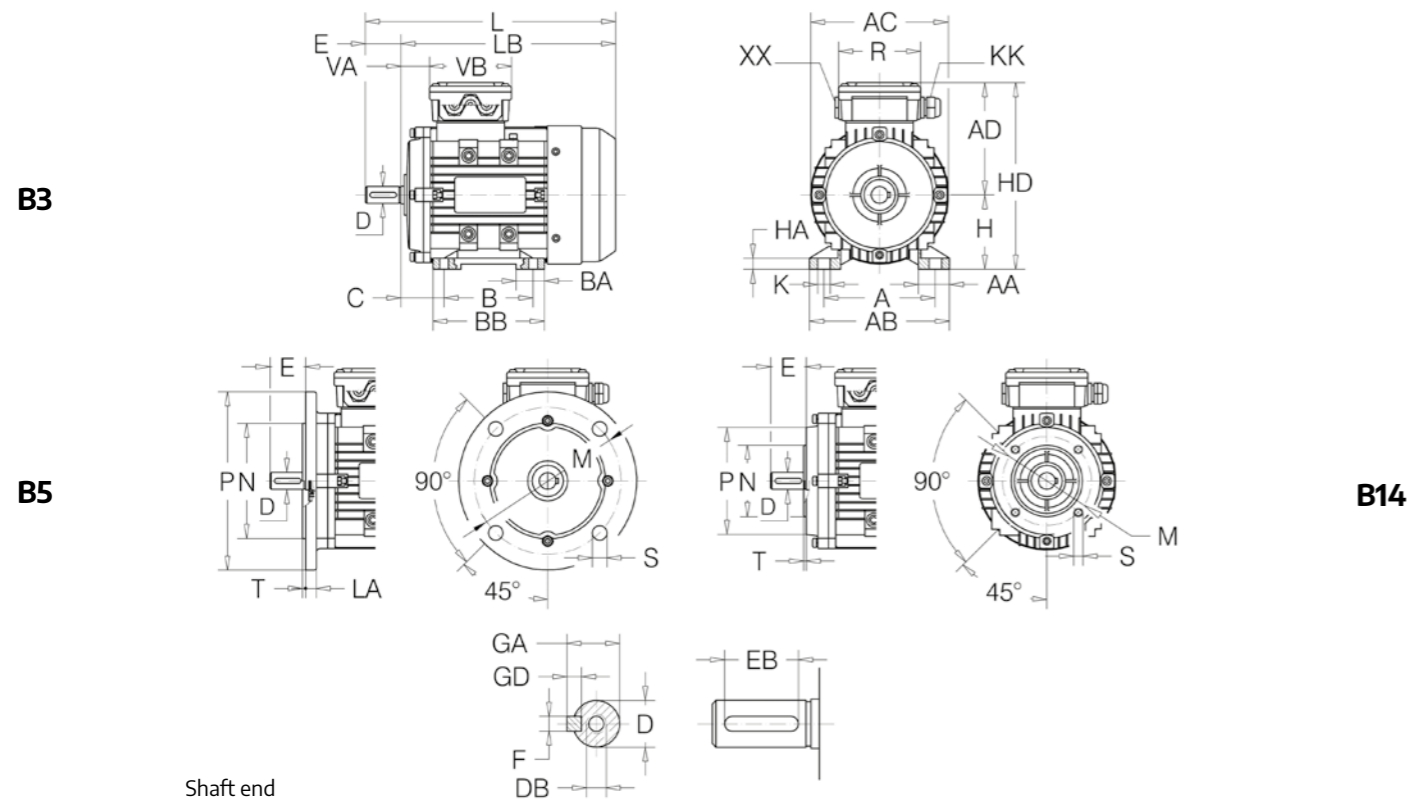

JM SERIES

Tab. 6.16.2

JM - JMD Motor	Shaft - End							Shaft - Seals						Terminal - Box						
	D	DB	E	GA	F	GD	EB	Flange-End			Drive End DE Non drive end NDE.			Term.	Flange-End					
								Øi	Øe	H	Øi	Øe	H	N°-Ø	N°-KK	N°-XX	VA	VB	R	
56	2-4-6	9	M4	20	10,2	3	3	14	12	25	7	12	25	7	6-M4	1-M20x1,5	1-plug	18	80	80
63	2-4-6	11	M4	23	12,5	4	4	16	12	25	7	12	25	7	6-M4	1-M20x1,5	1-plug	29	87	87
71	2-4-6-8	14	M5	30	16	5	5	25	15	30	7	15	30	7	6-M4	1-M20x1,5	1-plug	40	87	87
80	2-4-6-8	19	M6	40	21,5	6	6	30	20	35	7	20	35	7	6-M4	1-M20x1,5	1-plug	31	87	87
90	2-4-6-8	24	M8	50	27	8	7	40	25	40	7	25	40	7	6-M4	1-M25x1,5	1-plug	31	106	106
100	2-4-6-8	28	M10	60	31	8	7	50	30	47	7	30	47	7	6-M4	1-M25x1,5	1-plug	31	106	106
112	2-4-6-8	28	M10	60	31	8	7	50	30	47	7	30	47	7	6-M5	2-M25x1,5	--	35	114	122
132	2-4-6-8	38	M12	80	41	10	8	65	40	62	7	40	62	7	6-M5	2-M32x1,5	--	43	114	122
160	2-4-6-8	42	M16	110	45	12	8	90	45	62	12	45	62	12	6-M6	2-M40x1,5	1-M16x1,5	78	156	167

JM SERIES

Tab. 6.16.1

JM - JMD Motor	Main Overall Dimension							Feet								Flange								
	AC	AD	H	HD	LB	L	A	B	C	AB	BB	AA	BA	HA	K	IM	M	NJ6	P	LA	T	S		
56	2-4-6	112	97	56	153	170	190	90	71	36	110	90	30	21	8	6	B5	100	80	120	8	3	N°4 7	
																	B14	65	50	80	--	2,5	N°4 M5	
63	2-4-6	120	101	63	164	191	214	100	80	40	122	100	35	24	8	7	B5	115	95	140	10	3	N°4 10	
																	B14	75	60	90	--	2,5	N°4 M5	
71	2-4-6-8	137	108	71	179	212	242	112	90	45	133	110	35	24	8	7	B5	130	110	160	10	3,5	N°4 10	
																	B14	85	70	105	--	2,5	N°4 M6	
80	2-4-6-8	158	129	80	209	244	284	125	100	50	157	125	35	31	8	10	B5	165	130	200	12	3,5	N°4 12	
																	B14	100	80	120	--	3	N°4 M6	
90	S L	2-4-6-8	175	142	90	232	270 295	320 345	140	100 125	56	173	125 150	37	31	10	10	B5	165	130	200	12	3,5	N°4 12
																		B14	115	95	140	--	3	N°4 M8
100	L	2-4-6-8	198	156	100	256	338	398	160	140	63	196	172	40	39	11	12	B5	215	180	250	13	4	N°4 15
																		B14	130	110	160	--	3,5	N°4 M8
112	M	2-4-6-8	219	168	112	280	341	401	190	140	70	227	180	41	43	12	12	B5	215	180	250	14	4	N°4 15
																		B14	130	110	160	--	3,5	N°4 M8
132	S M	2-4-6-8	258	190	132	322	395 433	475 513	216	140 178	89	262	186 224	51	46	15	12	B5	265	230	300	14	4	N°4 15
																		B14	165	130	200	--	3,5	N°4 M10
160	M L	2-4-6-8	316	242	160	402	500 545	610 655	254	210 254	108	304	260 304	55	50	18	15	B5	300	250	350	15	5	N°4 19
																		B14	215	180	250	--	4	N°4 M12